



PERFORMANCE RANGE

- Flow rate up to **160 l/min** (9.6 m³/h)
- Head up to **58 m**

APPLICATION LIMITS

- Manometric suction lift up to **7 m**
- Liquid temperature between **-10 °C** and **+90 °C**
(up to +40 for the version with the technopolymer impeller)
- Ambient temperature up to **+40 °C**
- Max. working pressure:
 - **6 bar** for CP 100-130-132-150-158
 - **10 bar** for CP 170-190-200
- Continuous service **S1**

CONSTRUCTION AND SAFETY STANDARDS

EN 60034-1
IEC 60034-1
CEI 2-3



CERTIFICATIONS



INSTALLATION AND USE

Suitable for use with clean water and liquids that are not chemically aggressive towards the materials from which the pump is made. As a result of their reliability and the fact that they are easy to use, these pumps are widely used in domestic and civil applications such as the distribution of water in combination with small and medium sized pressure sets, for transferring liquids and for the irrigation of gardens and allotments. The pump should be installed in an enclosed environment, or at least sheltered from inclement weather.

PATENTS - TRADE MARKS - MODELS

- Registered Community Design n° 406160-0001

OPTIONALS AVAILABLE ON REQUEST

- Pump with technopolymer impeller
- Special mechanical seal
- Other voltages or 60 Hz frequency
- IP55 class protection for CP 170, CP 170M

GUARANTEE

1 year subject to terms and conditions

CHARACTERISTIC CURVES AND PERFORMANCE DATA

50 Hz n= 2900 1/min HS= 0 m

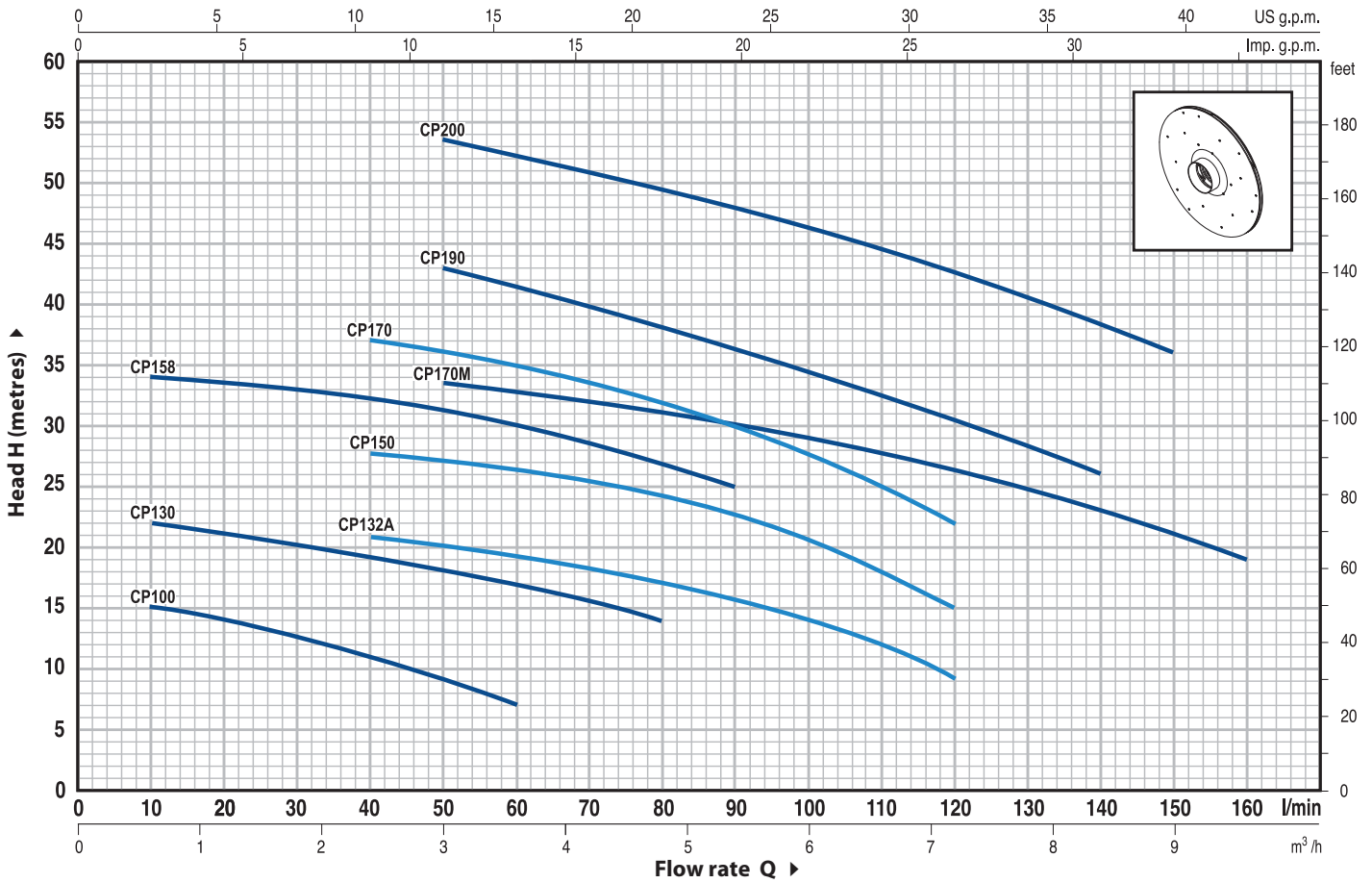

MODEL		POWER		Q	Flow rate																		
Single-phase	Three-phase	kW	HP		m³/h	0	0.6	1.2	1.8	2.4	3.0	3.6	4.2	4.8	5.4	6.0	6.6	7.2	7.8	8.4	9.0	9.6	
				l/min	0	10	20	30	40	50	60	70	80	90	100	110	120	130	140	150	160		
CPm 100	-	0.25	0.33	H metres	16	15	14	12.5	11	9	7												
CPm 130	CP 130	0.37	0.50		23	22	21	20	19	18	17	15.5	14										
CPm 132A	CP 132A	0.60	0.85		23	-	22	21.5	21	20	19	18	17	16	14	12	9						
CPm 150	CP 150	0.75	1		29.5	-	29	28.5	28	27.5	26.5	26	24.5	23	21	18	15						
CPm 158	CP 158	0.75	1		36	34	33.5	33	32.5	31.5	30	28.5	27	25									
CPm 170	CP 170	1.1	1.5		41	-	-	38	37	36	35	33.5	32	30	27.5	25	22						
CPm 170M	CP 170M	1.1	1.5		36	-	-	35	34.5	33.5	33	32	31	30	29	28	26.5	25	23	21	19		
CPm 190	CP 190	1.5	2		50	-	-	46	44.5	43	41.5	40	38	36	34.5	32.5	30.5	28	26				
-	CP 200	2.2	3		58	-	-	55	54.5	53.5	52	51	49.5	48	46	44.5	42.5	40.5	38.5	36			

Q = Flow rate H = Total manometric head HS = Suction height

Tolerance of characteristic curves in compliance with EN ISO 9906 App. A.

POS.	COMPONENT	CONSTRUCTION CHARACTERISTICS					
1	PUMP BODY	Cast iron, complete with threaded ports in compliance with ISO 228/1					
2	BODY BACKPLATE	Stainless steel AISI 304 (cast iron for CP 190-200)					
3	IMPELLER	Stainless steel AISI 304					
4	MOTOR SHAFT	Stainless steel EN 10088-3 - 1.4104					
5	MECHANICAL SEAL	Pump	Seal	Shaft	Materials		
		<i>Model</i>	<i>Model</i>	<i>Diameter</i>	<i>Stationary ring</i>	<i>Rotational ring</i>	<i>Elastomer</i>
		CP 100-130-132A	AR-12	Ø 12 mm	Ceramic	Graphite	NBR
		CP 150-158	AR-14	Ø 14 mm	Ceramic	Graphite	NBR
CP 170-170M-190-200	FN-18	Ø 18 mm	Graphite	Ceramic	NBR		
6	BEARINGS	Pump	Model				
		CP 100-130-132A	6201 ZZ / 6201 ZZ				
		CP 150-158	6203 ZZ / 6203 ZZ				
		CP 170-170M	6204 ZZ / 6204 ZZ				
		CP 190-200	6304 ZZ / 6204 ZZ				
7	CAPACITOR	Pump	Capacitance				
		<i>Single-phase</i>	<i>(230 V or 240 V)</i>	<i>(110 V)</i>			
		CPm 100	10 µF 450 VL	25 µF 250 VL			
		CPm 130	10 µF 450 VL	30 µF 250 VL			
		CPm 132A	14 µF 450 VL	30 µF 250 VL			
		CPm 150-158	20 µF 450 VL	60 µF 300 VL			
		CPm 170-170M	25 µF 450 VL	60 µF 250 VL			
		CPm 190	45 µF 450 VL	80 µF 250 VL			
8	ELECTRIC MOTOR	CPm: single-phase 230 V - 50 Hz with thermal overload protector built-in to the winding.					
		CP: three-phase 230/400 V - 50 Hz.					
		<p>➔ Pumps fitted with the three-phase motor option offer IE2 (IEC 60034-30) class high performance</p> <ul style="list-style-type: none"> - Insulation: F class. - Protection: IP 44. 					

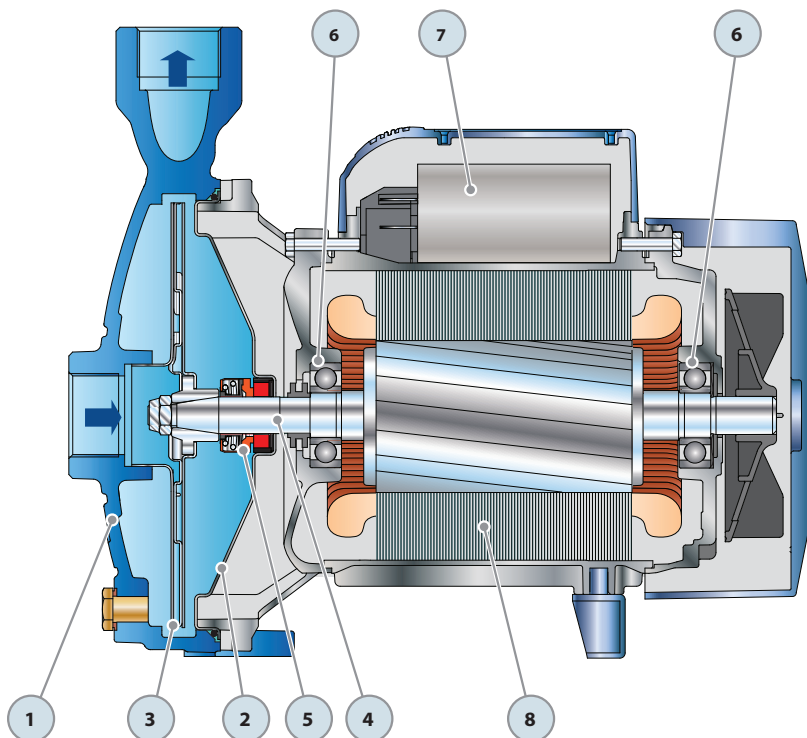

DIMENSIONS AND WEIGHT

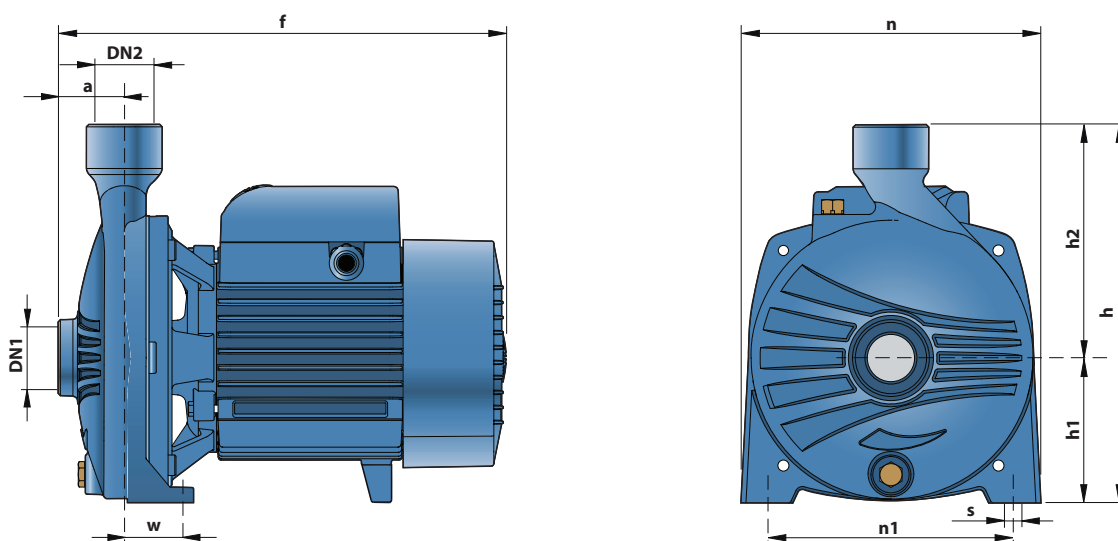

MODEL		PORTS		DIMENSIONS mm									kg	
Single-phase	Three-phase	DN1	DN2	a	f	h	h1	h2	n	n1	w	s	1~	3~
CPm 100	-	1"	1"	42	259	192	82	110	165	135	41	10	6.9	-
CPm 130	CP 130					205	82	123					7.6	7.1
CPm 132A	CP 132A					205	82	123					8.3	8.0
CPm 150	CP 150				285	92	148	12.4	11.4					
CPm 158	CP 158	1 1/4"	1"	51	367	240	110	150	190	160	38	11	12.0	11.0
CPm 170 - 170M	CP 170 - 170M				367	260	110	150	206	165	44.5		17.8	17.2
CPm 190	CP 190				364	290	115	175	242	206	32.5		22.3	21.3
-	CP 200	-	-	-	-	-	-	-	-	-	-	-	-	22.5

ABSORPTION

MODEL	VOLTAGE (single-phase)		
	230 V	240 V	110 V
Single-phase	230 V	240 V	110 V
CPm 100	1.9 A	1.55 A	3.3 A
CPm 130	3.2 A	2.9 A	6.4 A
CPm 132A	3.5 A	3.2 A	7.0 A
CPm 150	5.7 A	5.4 A	11.4 A
CPm 158	6.0 A	5.8 A	12.0 A
CPm 170 - 170M	7.8 A	7.2 A	16.0 A
CPm 190	11.0 A	10.0 A	22.0 A

MODEL	VOLTAGE (three-phase)			
	230 V	400 V	240 V	415 V
Three-phase	230 V	400 V	240 V	415 V
CP 130	2.0 A	1.2 A	1.8 A	1.1 A
CP 132A	2.9 A	1.7 A	2.4 A	1.4 A
CP 150	4.2 A	2.4 A	4.1 A	2.4 A
CP 158	4.4 A	2.5 A	4.3 A	2.5 A
CP 170 - 170M	5.2 A	3.0 A	5.1 A	2.9 A
CP 190	7.5 A	4.3 A	7.3 A	4.2 A
CP 200	9.0 A	5.2 A	8.3 A	4.8 A

PALLETIZATION

MODEL		GROUPAGE				CONTAINER			
Single-phase	Three-phase	n° pumps	H (mm)	kg		n° pumps	H (mm)	kg	
				1~	3~			1~	3~
CPm 100	-	105	1280	741	-	189	2190	1321	-
CPm 130	CP 130	105	1280	820	770	189	2190	1460	1360
CPm 132A	CP 132A	105	1280	890	860	189	2190	1590	1530
CPm 150	CP 150	70	1450	890	820	112	2240	1410	1300
CPm 158	CP 158	70	1450	860	790	112	2240	1360	1250
CPm 170	CP 170	50	1560	900	870	70	2120	1250	1200
CPm 170M	CP 170M	50	1560	940	910	70	2120	1310	1260
CPm 190	CP 190	36	1410	820	790	54	2040	1220	1170
-	CP 200	36	1410	-	830	54	2040	-	1240

